

Machine Bases



Model 700 and Model 900

Whatever you have to do - from building machinery, to mounting jigs and fixtures, to thousands of other industrial applications, Durant has just the right table for you. We offer these solidly welded, steel plate, extra rugged tables in 54 standard sizes. You also have your choice of a welded 3/4" thick unground table platen, or with a 1" or 1 1/2" thick ground platen which is bolted in place.

Model 700 has 1/8" thick legs. Model 900 has 1/4" thick legs.

Standard Heights:

24", 30", 36" available. Special heights and sizes also available. Standard tables have tops Blanchard ground one side only.

For critical flatness, tops can be normalized and ground on both sides at an additional cost.

Options:

- Aluminum Jig Plate Top
- Special Sizes and Heights to Customer's Specifications

MACHINE BASES	
Length Left to Right (Inches)	Width Front to Back (Inches)
24	24
	30
	36
	42
30	30
	36
	42
	48
36	36
	42
	48
	60
42	42
	48
	60
48	48
	60

- 54 Standard Sizes
- Frame Only Available
- Special Sizes
- Special Heights

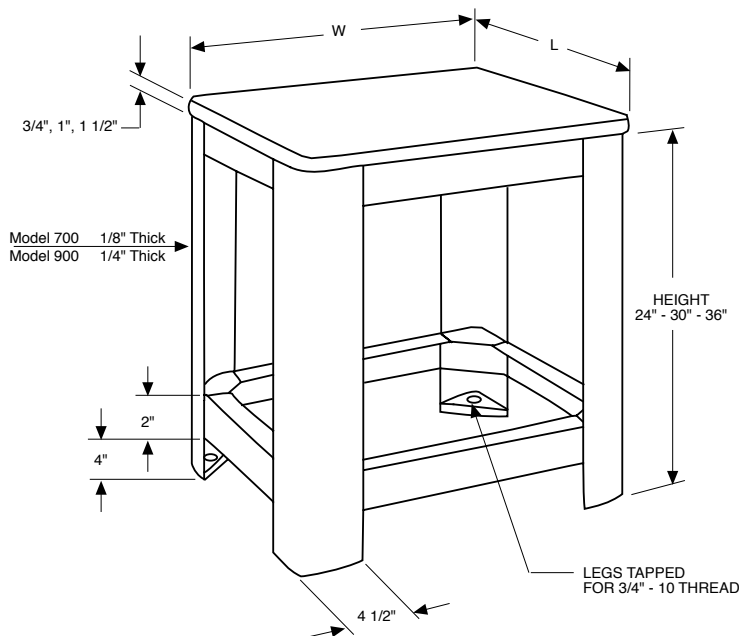

Model 1000

When you have extra heavy duty applications for mounting tools or machinery, the Model 1000 has a solid frame constructed with 3 x 3 x 1/4" thick square tubing. Available standard tops are 1" or 1-1/2" thick ground platen, bolted in place.

Standard Heights:

24", 30", 36" available. Special heights and sizes also available. Standard tables have tops Blanchard ground one side only. For critical flatness, tops can be normalized and ground on both sides at an additional cost.

Options:

- Aluminum Jig Plate Tops
- Special Sizes and Heights to Customer's Specifications