

Durant Tool Company

Wire Handling Equipment Catalog

Wire Straighteners  *Cut-to-Length Machines*

Wire Uncoilers *Wire Straighteners*

Servo Wire Feeders *Traversing Units*

Wire Guides *Pneumatic Cutters*

Traversing Units *Wire Straighteners*



Servo Wire Feeders *Wire Feeders*

www.durantco.com

Wire Uncoilers

Cut-to-Length Machines *Wire Straighteners*

Wire Payoffs

Uncoiling wire is simple and trouble-free when using the Durant Variable Speed Motorized Wire Payoffs. Only the Durant Wire Payoff eliminates the problems associated with wire twists and tangles. The positive drive system smoothly pays out the wire through a heavy duty guiding system with built in accumulator. The "quick response" regenerative drive feeds the wire accurately to your wire forming machine. If your wire stands are loaded in the opposite manner, a flip of the switch quickly reverses the turntable rotation.

STANDARD FEATURES:

- Wire stand locks.
- Accumulator/wire guide.
- Regenerative drive / braking.
- Coil stand lock.

OPTIONS:

- Special color (black standard).
- Larger turntable diameter and/or weight capacity.
- Faster turntable RPM.



Model #W-3550-42

WIRE UNCOILER SPECIFICATIONS

Model	Weight Capacity	Max. Turntable RPM	Turntable Diameter	Motor H.P.
W-1025-30	1000 lbs.	0-25	30"	3/4
W-1050-30	1000 lbs.	0-50	30"	3/4
W-1070-30	1000 lbs.	0-70	30"	3/4
W-2025-42	2000 lbs.	0-25	42"	1
W-2050-42	2000 lbs.	0-50	42"	1
W-2070-42	2000 lbs.	0-70	42"	1
W-3525-42	3500 lbs.	0-25	42"	1
W-3550-42	3500 lbs.	0-50	42"	1
W-3570-42	3500 lbs.	0-70	42"	1
W-5050-48	5000 lbs.	0-50	48"	2

No Mechanical Contraptions to Fool with!

No Drive Wheels that Wear and Slip!

You make \$\$\$ with the Durant Wire Payoff and Uncoilers. Durant Uncoilers are Productivity Performers! We Guarantee it!



Pallet Decoilers

When your uncoiling application calls for pallet decoilers, it's time to call Durant. Why?

- (1) Durant has more than 60 years experience in uncoiling all types of materials in probably every type of application.
- (2) Durant manufactures the largest selection of pallet decoilers and also vertical (traditional) uncoilers.
- (3) Durant offers a standard 3 year warranty on all uncoilers.
- (4) Durant product engineering, quality, manufacturing and components are rated #1.
- (5) Durant pricing is always at the most competitive levels.
- (6) Durant customer service specialists are a team focusing on your needs. We're not satisfied until you are!

FEATURES:

- No dangerous turntable pinch points (Note: Other manufacturers have many casters and drive wheels under turntable creating dangerous pinch point for operator's fingers.)
- Heavy duty, rugged turntable and base construction.
- 3 year warranty.
- Reverse turntable direction rotation with flip of the switch. No mechanical adjustments or torque systems to install.
- No drive wheels or casters to clean or replace.
- Easy loading of entire pallets of coil stock.
- Requires no slack loop. Can be placed within 2 feet of press.
- Models to 12,000 lb. capacity.
- Speeds to 70 rpm.
- Turntable diameters to 72" O.D.
- Special material guide drums to 24" wide.
- Urethane drum option.
- Coil lock option.
- Rubber anti-slip turntable mat option.
- Special sizes to customer specifications.
- Custom paint colors to customer specifications.
- Quick response regenerative drive that enhance acceleration and deceleration option.
- Versatile machine that handles most press, roll forming, and wire forming applications.

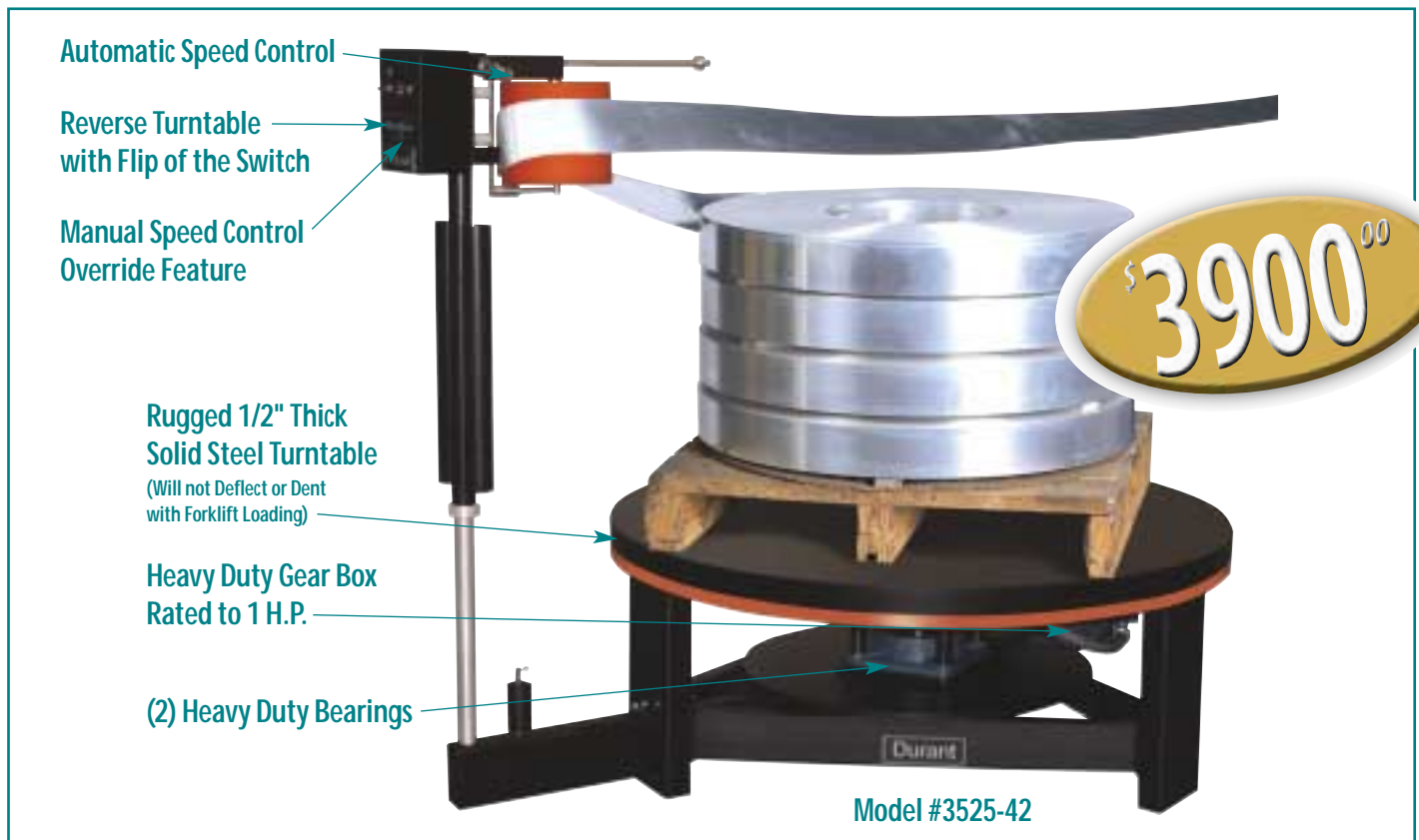

Wire Feeders

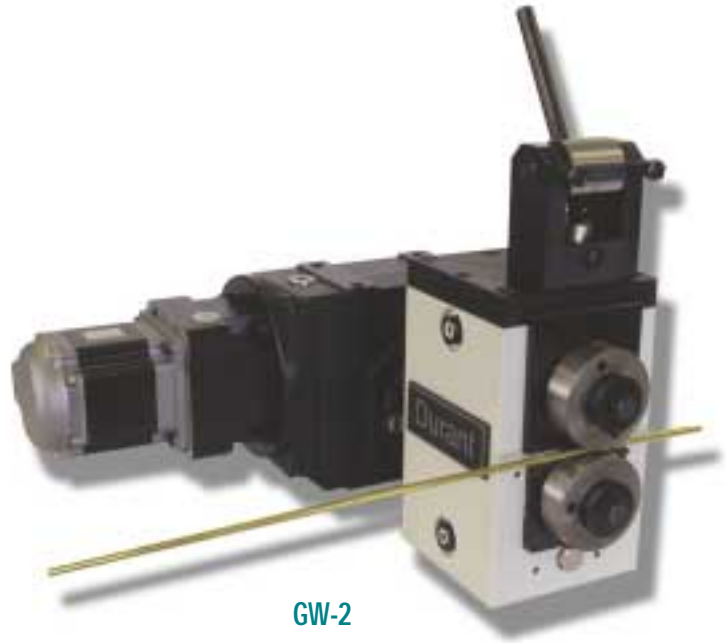

GW-2



GW-3

WIRE FEEDER SPECIFICATIONS

Model	Pulling Capacity	Number Drive Rolls	Roll Diameter
GW-1	150 lbs.	2	2.56"
GW-2	300 lbs.	2	2.56"
GW-3	500 lbs.	4	2.56"

Mechanical Roll Release Standard

OPTIONS:

- Pneumatic Roll Release
- Hydraulic Roll Release
- Pneumatic Cutters for Cut-to-Length
- Hydraulic Cutters for Cut-to-Length
- Heavy Duty Adjustable Mounting Bracket

You make \$\$\$ with the Durant Wire Payoff and Uncoilers. Durant Uncoilers are Productivity Performers! We Guarantee it!



Wire Straighteners • Traditional Type

Model WS Wire Straighteners

Durant Wire Straighteners are used for straightening round or flat wire as well as wire with irregular cross sections. Each unit consists of two sets of 5 or 7 "V" grooved rolls set at right angles as illustrated to remove the material curvature on both planes. The rolls on Durant Wire Straighteners can be grooved to the exact diameter of the wire to be straightened or can be "V"-grooved (standard) for handling a wide range of sizes.

Features of Construction:

- Adjustable Rolls - Each roll can be individually adjusted by means of a socket screw set for proper straightening action.
- Ball Bearing - Each roll is mounted on a hardened Spindle Set in ball bearings for long life.



WS-007

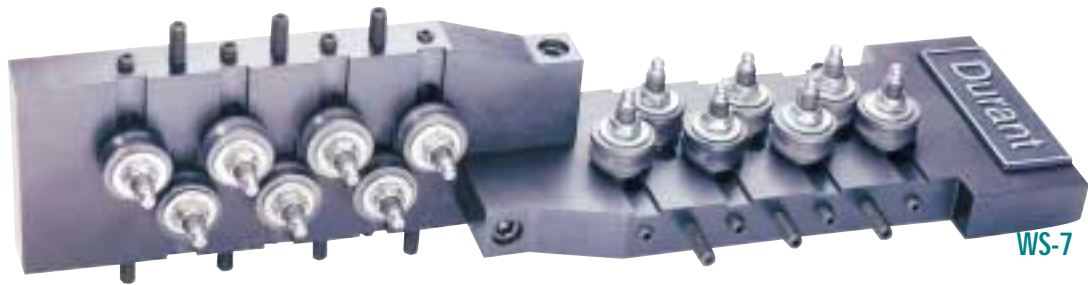

WS-7



WS-7H

WS WIRE STRAIGHTENERS

Model	Number of Rolls*	Diameter Rolls	Wire Size	Weight
WS-007	14	3/4"	Up to .062	8 lbs.
WS-5	10	1 3/16"	Up to .1875	25 lbs.
WS-7	14	1 3/16"	Up to .1875	30 lbs.
WS-5H	10	2 1/4"	Up to .375	60 lbs.
WS-7H	14	2 1/4"	Up to .375	75 lbs.

OPTION:

All Durant wire straighteners can be installed with powered drive rolls to give you an automated powered wire straightening machine. Call Durant!

If You Can't Find What You Want To Order...

Call 1-800-338-7268

OR

Fax 1-401-738-2586

Wire Straighteners

Quick Adjust Type Multi Purpose

Quick Adjust Type Model

Durant Wire Straighteners are ideal for multi purpose general applications that require the roll settings to remain in the same positions when changing spools or coils.

SINGLE PLANE				
Model	Number of Rolls	Diameter Rolls	Line Speed Feet/Second	Wire Diameter
QS13	7	.510"	75	Customer to Specify
QS16	7	.630"	75	
QS22	7	.905"	60	
QS30	7	1.250"	60	
QS40	7	1.650"	45	
QS47	7	1.850"	30	
QS62	7	2.560"	15	
QS80	7	3.150"	10	



QS

DUAL PLANE				
Model	Number of Rolls	Diameter Rolls	Line Speed Feet/Second	Wire Diameter
DQS13	10	.510"	75	Customer to Specify
DQS16	10	.630"	75	
DQS22	10	.905"	60	
DQS30	10	1.250"	60	
DQS40	10	1.650"	45	
DQS47	10	1.850"	30	
DQS62	10	2.560"	15	
DQS80	10	3.150"	10	



DQS

When your application requires straightening and feeding wire to a precise length, look to Durant. Our space saving economical wire straighteners/feeders will handle most applications.



Wire Straighteners

Quick Adjust Type Spring and Screw Machine Application



DQM SERIES

DUAL PLANE				
Model	Number of Rolls	Diameter Rolls	Line Speed Feet/Second	Wire Diameter
DQM13	18	.510"	90	Customer to Specify
DQM16	18	.630"	90	
DQM22	18	.866"	90	
DQM32	18	1.256"	60	
DQM40	18	1.575"	60	
DQM52	18	2.047"	30	
DQM65	18	2.560"	15	
DQM90	18	3.543"	15	



QM SERIES

**If You Can't Find
What You
Want To Order...
Call 1-800-338-7268
OR
Fax 1-401-738-2586**

SINGLE PLANE				
Model	Number of Rolls	Diameter Rolls	Line Speed Feet/Second	Wire Diameter
QM13	9	.510"	90	Customer to Specify
QM16	9	.630"	90	
QM22	9	.866"	90	
QM32	9	1.256"	60	
QM40	9	1.575"	60	
QM52	9	2.047"	30	
QM65	9	2.560"	15	
QM90	9	3.543"	15	

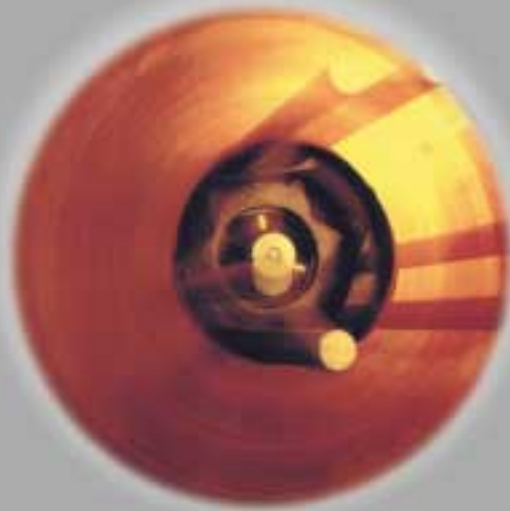
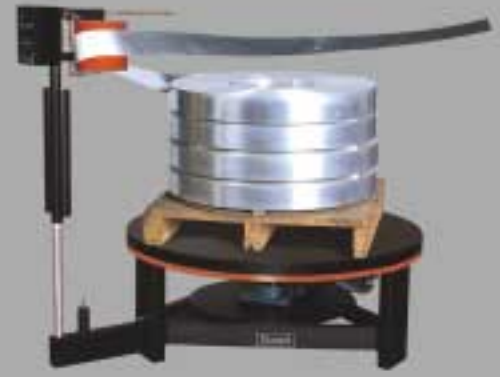

Durant Tool Company

200 Circuit Drive
North Kingstown, RI 02852 USA
(401) 781-7800
(800) 338-7268
Fax: (401) 738-2586

www.durantco.com

